



ENGINE

Model	FPT F5H FL463 B*F001
Emissions Certification	Tier 4 Final
Type	4-stroke
Cylinders	4
Bore/Stroke	3.9 x 4.3 in (99 x 110 mm)
Displacement	207 in ³ (3.4 L)
Fuel injection	High pressure, common rail injection
Fuel	Diesel
Fuel filter	Spin on, Beta (4) = 20
Air filter	Dry type element w/ warning restriction indicator
Exhaust aftertreatment:	Particulate Matter Catalyst – PM Catalyst
Radiator:	
Core type	All aluminum
Fan:	
Style	Direct drive
Lubrication/cooling oil pump:	
Style	Integral
Engine oil:	
Pump:	
	Deep sump plate cooler w/ pressurized under-piston nozzles
Pump operating angle ratings:	
Side-to-side	Rated 35°
Fore and aft	Rated 35°
Oil filtration	Spin on, full flow
Engine speeds	RPM
Rated – full load	2500
Low idle	950
High idle – no load	2500
Horsepower @ 2500 RPM:	
Gross	58 hp (43 kW)
Net	55 hp (41 kW)
Peak torque @ 1400 RPM:	
Gross	181 lb-ft (245 N-m)
Net	181 lb-ft (245 N-m)

NOTE: Gross horsepower and torque per SAE J1349.
Net horsepower and torque per SAE J1349.

DRIVETRAIN

Transmission	Hydrostatic transmission	
Pump relief	6,092 psi (42 000 kPa)	
Pump flow @ 2500 RPM	26.4 gpm (100 L/min)	
Differential:	Open standard/limited slip optional	
Front axles:		
Differential ratio	3.67	
Planetary ratio	6.00	
Final axle ratio	22.00	
Gear box:		
1st ratio	1.85	
Planetaries	Outboard	
Service brakes:	Master cylinder hydraulically actuated, caliper on front axle	
Parking brake:	Mechanical, caliper on front axle	
Travel speeds	Forward	Reverse
	mph (kph)	mph (kph)
1st Low	3.1 (5.0)	3.1 (5.0)
2nd High	12.4 (20.0)	12.4 (20.0)

ELECTRICAL

Voltage	12 Volts
Alternator	120 amp
Batteries	95 AHR, 900 CCA

OPERATOR ENVIRONMENT

Base and Deluxe Cab w/ heater; Key start; Articulated power steering w/ tilt column; Full adjustable, cloth suspension seat; Foot throttle; Single joystick w/ electronic speed shift control F/N/R switch and proportional loader control; Cup holder; Retractable seat belt; Storage tray on Deluxe Cab; Sun screen – front; Opening side window; Dome light; Wipers – front and rear; 12-volt auxiliary power; Lighter cigar and ashtray; Pocket cellular phone; Coat hook; External rearview mirrors; Loader control lockout.

Electronic information center

Displays/Gauges:
Vehicle speed; Hourmeter; Floating functionality on; Clock; Vehicle directions; Gear number engaged; PM Catalyst icons.

Indicator lights:
Main hydraulic enabled; Turn light – left and right; Rear work lamps; Work lamps; Main high beam; Side lights; Stop; Warning signal; Rabbit; Hand brake; Brake fluid level; Quick coupler on; Ride Control on; Creep speed; PM Catalyst; Low fuel level; Clogging air filter; Engine oil pressure; Glow plug; Alternator changing.

Audible alarms:
Caution alarm; Critical alarm; Backup alarm.

Horn

NOTE: If equipped w/ option.

OPERATING WEIGHT

XT:
Unit equipped w/ ROPS/FOPS cab w/ heater, standard counterweight, 12.5-18 PRMPT Dunlop Tires, front and rear fenders, 0.9 yd³ (0.7 m³) general purpose bucket w/ edge, full fuel, 165 lb (75 kg) operator:
10,913 lb (4 950 kg)

Z-Bar:
Unit equipped w/ ROPS/FOPS cab w/ heater, standard counterweight, 12.5-18 PRMPT Dunlop Tires, front and rear fenders, 0.9 yd³ (0.7 m³) general purpose bucket w/ edge, full fuel, 165 lb (75 kg) operator:
11,272 lb (5 113 kg)

HYDRAULICS

Pump – steering/implement:
Open-centered pressure/flow compensated

Fixed gear type:
Max. 17.7 gpm @ 2500 RPM @ 3,626 psi
(Max. 67 L/min @ 2500 RPM @ 25 000 kPa)

Loader control valve:
Open-center, Hydraulic Loader Control w/ single lever includes: Forward/Neutral/Reverse switch, Floating switch, Low/High Travel mode switch, Auxiliary Function Roller

Loader auxiliary steering:
Hydraulic orbital center-pivot articulating w/ on-demand oil flow

Main relief pressure 3,336 psi (23 000 kPa)

Filtration:
15-micron, full flow replaceable cartridges on return line

SERVICE CAPACITIES

Fuel tank	22.7 gal (86.0 L)
Hydraulic system:	
Reservoir	10.6 gal (40.0 L)
Total	14.0 gal (53.0 L)
Front and rear axle:	
Front axle	2.2 gal (8.2 L)
Rear axle	2.5 gal (9.5 L)
Engine oil w/ filter	1.8 gal (7.0 L)
Cooling*	3.4 gal (13.0 L)

NOTE: *1.72 gal (6.5 L) antifreeze + 1.72 gal (6.5 L) water.

OTHER SPECIFICATIONS

Lift cylinder – XT	One (1)
Bore diameter	4.0 in (101.6 mm)
Rod diameter	2.0 in (50.8 mm)
Stroke	23.6 in (600.0 mm)
Dump cylinder – XT:	
Bore diameter	4.0 in (101.6 mm)
Rod diameter	2.0 in (50.8 mm)
Stroke	15.4 in (391.0 mm)

Lift cylinder – Z-Bar	Two (2)
Bore diameter	2.8 in (70.2 mm)
Rod diameter	2.0 in (50.8 mm)
Stroke	28.7 in (728.0 mm)

Dump cylinder – Z-Bar:	
Bore diameter	3.3 in (82.6 mm)
Rod diameter	1.8 in (44.5 mm)
Stroke	19.4 in (491.5 mm)

Loader:	
XT:	
Parallel loader linkage	
Single control for lift and tilt	
Positive hold float	
Hydraulic attachment coupler:	
Skid steer compatible/horizontal pin compatible	

Z-Bar:	
Z-Bar loader linkage	
Single control for lift and tilt	
Positive hold float	
Hydraulic attachment coupler:	
Skid steer compatible/horizontal pin compatible	

Cycle time:	
XT:	
Raise w/ rated bucket load	4.6 sec
Dump w/ rated bucket load	1.4 sec
Lower – empty	3.8 sec
Z-Bar:	
Raise w/ rated bucket load	6.3 sec
Dump w/ rated bucket load	1.7 sec
Lower – empty	3.8 sec

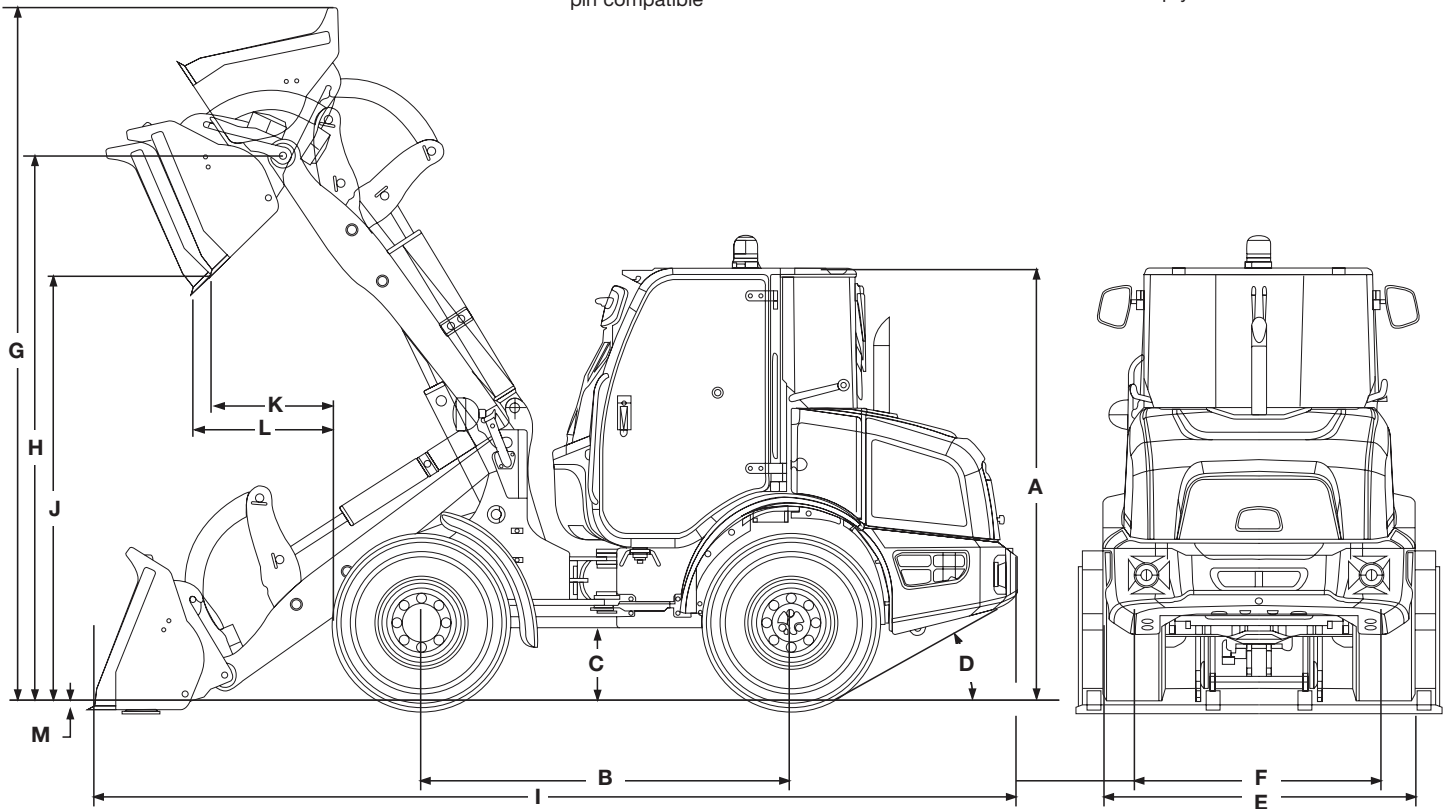

Line drawings are for illustrative purpose only and may not be exact representation of unit.

DIMENSIONS

A. Height to top of ROPS cab	96.8 in (2 458 mm)
B. Wheelbase	81.7 in (2 075 mm)
C. Ground clearance under shaft	17.5 in (444 mm)
Ground clearance under axles	12.6 in (321 mm)
D. Angle of departure	28°
Width:	
E. Overall without bucket	68.5 in (1 740 mm)
F. Centerline tread	55.1 in (1 400 mm)
Turning radius – outside	146.5 in (3 721 mm)
Turning angle:	
From center	40°
Total angle	80°
Rear axle oscillation – total	18°

PERFORMANCE SPECS

21F XT	0.92 yd³ GP (0.7 m³) GP Bucket with Bolt-on Edge	1.05 yd³ GP (0.8 m³) LM Bucket with Bolt-on Edge
ISO bucket capacity – struck	0.65 yd ³ (0.5 m ³)	0.78 yd ³ (0.6 m ³)
Heaped	0.92 yd ³ (0.7 m ³)	1.05 yd ³ (0.8 m ³)
Bucket width – outside	74.8 in (1 900 mm)	80.7 in (2 050 mm)
Bucket weight – includes coupler and added components	904 lb (410 kg)	946 lb (429 kg)
G. Operating height – fully raised with spillguard	159.3 in (4 046 mm)	159.1 in (4 041 mm)
H. Hinge pin height – fully raised	122.6 in (3 113 mm)	122.6 in (3 113 mm)
I. Overall length – bucket level on ground	211.9 in (5 382 mm)	212.3 in (5 393 mm)
Dump angle – fully raised	44°	44°
J. Dump height – fully raised, 45° dump	90.0 in (2 287 mm)	89.6 in (2 276 mm)
K. Bucket reach – fully raised, 45° dump	31.4 in (798 mm)	31.9 in (809 mm)
L. Bucket reach – 7 ft 0 in (2.13 m) height, 45° dump	38.3 in (974 mm)	38.3 in (974 mm)
M. Dig depth	5.0 in (127 mm)	5.0 in (127 mm)
Operating load – ISO	3,527 lb (1 600 kg)	3,452 lb (1 566 kg)
Maximum material density – ISO	3,853 lb/yd ³ (2 286 kg/m ³)	3,299 lb/yd ³ (1 958 kg/m ³)
Tipping load – ISO:		
Straight	8,164 lb (3 703 kg)	7,994 lb (3 626 kg)
40° turn	7,055 lb (3 200 kg)	6,905 lb (3 132 kg)
Lift capacity:		
Full height	5,287 lb (2 398 kg)	5,163 lb (2 342 kg)
Maximum reach	5,933 lb (2 691 kg)	5,825 lb (2 642 kg)
Ground	6,336 lb (2 874 kg)	6,184 lb (2 805 kg)
Breakout force with tilt cylinder	6,753 lb (3 063 kg)	6,614 lb (3 000 kg)
Maximum rollback:		
@ Ground	38°	38°
@ Carry position	45°	45°
@ Maximum reach	53°	53°
@ Full height	56°	56°
Maximum grading angle with bucket – back dragging	73°	73°
Loader clearance circle with bucket	337.5 in (8 572 mm)	347.6 in (8 828 mm)

PERFORMANCE SPECS

21F Z-Bar	0.92 yd³ GP (0.7 m³) GP Bucket with Bolt-on Edge	1.31 yd³ GP (1.0 m³) LM Bucket with Bolt-on Edge
ISO bucket capacity – struck	0.65 yd ³ (0.5 m ³)	1.05 yd ³ (0.8 m ³)
Heaped	0.92 yd ³ (0.7 m ³)	1.31 yd ³ (1.0 m ³)
Bucket width – outside	74.8 in (1 900 mm)	80.7 in (2 050 mm)
Bucket weight – includes coupler and added components	972 lb (441 kg)	1,091 lb (495 kg)
G. Operating height – fully raised with spillguard	160.3 in (4 072 mm)	165.8 in (4 211 mm)
H. Hinge pin height – fully raised	123.5 in (3 136 mm)	123.5 in (3 136 mm)
I. Overall length – bucket level on ground	218.5 in (5 549 mm)	221.9 in (5 636 mm)
Dump angle – fully raised	47°	47°
J. Dump height – fully raised, 45° dump	90.6 in (2 302 mm)	88.2 in (2 240 mm)
K. Bucket reach – fully raised, 45° dump	37.7 in (957 mm)	40.1 in (1 018 mm)
L. Bucket reach – 7 ft 0 in (2.13 m) height, 45° dump	44.7 in (1 135 mm)	44.7 in (1 136 mm)
M. Dig depth	2.8 in (71 mm)	2.8 in (71 mm)
Operating load – ISO	3,499 lb (1 587 kg)	3,481 lb (1 579 kg)
Maximum material density – ISO	3,821 lb/yd ³ (2 267 kg/m ³)	2,486 lb/yd ³ (1 579 kg/m ³)
Tipping load – ISO:		
Straight	8,291 lb (3 761 kg)	8,351 lb (3 788 kg)
40° turn	6,997 lb (3 174 kg)	6,850 lb (3 107 kg)
Lift capacity:		
Full height	7,050 lb (3 198 kg)	6,947 lb (3 151 kg)
Maximum reach	9,018 lb (4 090 kg)	8,891 lb (4 033 kg)
Ground	10,938 lb (4 961 kg)	10,725 lb (4 865 kg)
Breakout force with tilt cylinder	9,199 lb (4 172 kg)	8,298 lb (3 764 kg)
Maximum rollback:		
@ Ground	38°	38°
@ Carry position	46°	46°
@ Maximum reach	67°	67°
@ Full height	71°	71°
Maximum grading angle with bucket – back dragging	47°	48°
Loader clearance circle with bucket	345.9 in (8 786 mm)	353.4 in (8 977 mm)

FORKS

21F XT	
Fork length	47.2 in (1 200 mm)
Fork weight – includes coupler	869 lb (394 kg)
Operating load – level ground	4,187 lb (1 899 kg)
Tipping load – straight	6,056 lb (2 747 kg)
Tipping load – 40° turn	5,234 lb (2 374 kg)
Fork load center	19.7 in (500 mm)
21F Z-Bar	
Fork length	47.2 in (1 200 mm)
Fork weight – includes coupler	869 lb (394 kg)
Operating load – level ground	3,902 lb (1 770 kg)
Tipping load – straight	5,651 lb (2 563 kg)
Tipping load – 40° turn	4,879 lb (2 213 kg)
Fork load center	19.7 in (500 mm)

STANDARD EQUIPMENT

OPERATOR ENVIRONMENT

See page 1

ENGINE

FPT F5H FL463 B*F001
Fuel filter with water trap
Dual element air cleaner

LOADER

See page 2

DRIVETRAIN

4-wheel drive
Open – front and rear axles
Hydrostatic transmission
Single joystick with electronic speed shift control F/N/R switch and proportional loader control
Outboard planetary axles
Dry disc brakes
Mechanical parking brake

HYDRAULICS

Hydraulic remote control
3-spool loader control valve
3 Diagnostic quick couplers

OTHER

Front and rear fenders
Lights:
2 Front driving headlights – high/low beam
2 Rear flood lights
2 Stop tail lights and backup light
Front and rear turn signal/flash
Drawbar pin
Articulation locking pin
Tie-down and Lift-up point – front and rear
Backup alarm
Wired for radio
Bucket position indicator

OPTIONAL EQUIPMENT

OPERATOR ENVIRONMENT

Creep speed 0 – 3.1 mph (5 kph)
TeleScop adjustable steering column on Deluxe Cab
Rotating beacon
Limited slip – front and rear axles
Mechanical coupler
Horizontal pin coupler
Air conditioning
Radio ready antenna and speakers

LOADER

Additional auxiliary flow:
Max. 17.7 gpm @ 2500 RPM @ 3,626 psi
(Max. 67 L/min @ 2500 RPM @ 25 000 kPa)
Buckets – see performance data:
General purpose standard
General purpose light material
4-IN-1®
STD forks
Tilttable Ride Control
Return to dig

TIRES

12.5-18 1PRMPT-04TBL MITAS
335/80 R18 EM MITAS
335/80 R18 SPT9 L2 DUNL – Standard
365/70 R18 EM MITAS
365/70 R18 SPT9 L2 DUNL

OTHER

Tool box
Counterweight:
330 lb (150 kg)
Mounts on rear chassis

CaseCE.com

©2016 CNH Industrial America LLC. All rights reserved. CASE is a trademark registered in the United States and many other countries, owned by or licensed to CNH Industrial N.V., its subsidiaries or affiliates. CNH Industrial Capital is a trademark in the United States and many other countries, owned by or licensed to CNH Industrial N.V., its subsidiaries or affiliates. Printed in U.S.A. Contains 10% post-consumer fiber.

IMPORTANT: CASE Construction Equipment Inc. reserves the right to change these specifications without notice and without incurring any obligation relating to such change. Availability of some models and equipment builds vary according to the country in which the equipment is used. The illustrations and text may include optional equipment and accessories and may not include all standard equipment. Your CASE dealer/distributor will be able to give you details of the products and their specifications available in your area.



CASE Construction Equipment is biodiesel-friendly. NOTE: All engines meet current EPA emissions regulations. All specifications are stated in accordance with SAE Standards or Recommended Practices, where applicable.



Always read the Operator's Manual before operating any equipment. Inspect equipment before using it, and be sure it is operating properly. Follow the product safety signs and use any safety features provided.

Form No. CCE20160321F
Replaces Form No. CCE20150421F