



ENGINE

Model	Isuzu AP-4LE2X
Emissions Certification	Tier 4 Final
Fuel	Requires ultra low-sulfur fuel B5 biodiesel tolerant
Type	Water-cooled, 4-cycle, high pressure common rail system. Turbo-charged w/ air cooled intercooler, DOC system
Cylinders	4-cylinder in-line
Displacement	133 in ³ (2.2 L)
Bore/Stroke	3.35 x 3.78 in (85 x 96 mm)
Fuel injection	Direct injection – electronic
Fuel filter	Replaceable, full flow spin-on cartridge
Air filter	Dry type element w/ warning restriction indicator
Oil filter	Replaceable, full flow spin-on cartridge
Engine gradeability:	
Side-to-side	35°
Fore and aft	35°
Net horsepower – SAE J1349 @ 2000 RPM:	53.6 hp (40 kW)
Net max. torque – SAE J1349 @ 1800 RPM:	142 lb-ft (193 N-m)
Cooling operating range:	109.4° to -13° F (43° to -25° C)
Oil	Requires low-ash oil CJ-4

DRIVETRAIN

Travel control	Dual stage relief/ counter balance design
Brakes	Mechanical disc
Service brakes	SAHR disc – each motor
Two speed travel:	
Max. high speed	3.2 mph (5.1 kph)
Max. low speed	2.0 mph (3.2 kph)
Automatic downshift	
Drawbar pull	13,400 lb (59.5 kN)
Gradeability	70% – 35° Slope

ELECTRICAL

Voltage	24 Volts
Alternator rating	50 amp
Batteries	2 x 12 Volt
Battery reserve capacity	64 Ah/5 hour
Work lights	24 Volt
1 boom	70 watt
1 upper	70 watt
1 house	55 watt

OPERATOR ENVIRONMENT

FOPS Level 1 cab top guard; Pressurized cab; One-touch lock front window; AC/heat/defrost w/ auto climate control; 6 watt interior dome light; Mechanical-suspension cloth seat; Adjustable armrest; Low-effort joystick controls; Controls pre-wired for auxiliary; Blade control lever; AM/FM radio w/ antenna and 2 speakers; Anti-theft start code system; Rubber floor mat; 12-volt electric socket; 24-volt cigarette lighter; External rear view mirrors; Windshield wiper/washer; Cup holder; Storage compartments; Travel alarm w/ cancel switch; One key start and lock-up; Built-in full-color LCD monitor; Safety glass for all windows; Polycarbonate roof hatch.

Air conditioner output	13,490 BTU/hr
Heater output	12,900 BTU/hr
Sound level inside cab – ISO6395	73.0 dBA

ATTACHMENT

Boom	11 ft 6 in (3 500 mm)
Arm option:	
Standard	5 ft 7 in (1 690 mm)
Bucket digging force	12,800 lbf (56.9 kN)

OPERATING WEIGHT

Operating weight	18,900 lb (8 590 kg)
w/ shoes	1 ft 6 in (450 mm)
w/ boom	11 ft 6 in (3 500 mm)
w/ arm	5 ft 7 in (1 690 mm)
w/ bucket	463 lb (210 kg)
w/ dozer blade	7 ft 7 in (2 320 mm)
w/ counterweight	2,430 lb (1 100 kg)

NOTE: W/ operator/full fuel/standard equipment.

DOZER BLADE

Blade width	91.3 in (2 320 mm)
Blade height	17.7 in (450 mm)
Max. lift above ground level	17.3 in (440 mm)
Max. drop below ground	11.0 in (280 mm)

GROUND PRESSURE

@ Standard operating weight 5.5 psi (0.38 bar)
w/ 17.7 in (450 mm) triple semi-grouser shoes

HYDRAULICS

System design	Open center
Main pumps	Two variable displacement/ axial piston
Max. rated flow per pump:	19.5 gpm (74 L/min)
Max. rated flow total:	39.1 gpm (148 L/min)

System pressures:	
Boom, arm and bucket	4,260 psi (294 bar)
Boom swing circuit	4,260 psi (294 bar)
Travel circuits	4,260 psi (294 bar)
Swing circuit	3,280 psi (226 bar)

Pilot pump	1 x gear design
Max. capacity	4.8 gpm (18 L/min)

Blade pump	1 x gear design
Max. flow	9.4 gpm (35.4 L/min)

Controls w/ boom/arm holding valve
Right track travel, bucket, boom, arm
acceleration and boom swing.

Left track travel, auxiliary, swing, boom
acceleration and arm.

Work mode selections SP: Speed Priority
H: Heavy-Duty
A: Automatic

Swing motor Fixed displacement
axial piston

Swing final drive Planetary gear reduction

Travel motor Two-speed independent
travel/axial piston

HYDRAULIC CYLINDERS

Boom cylinders	One (1)
Cylinder bore	4.5 in (115 mm)
Cylinder rod diameter	3.0 in (75 mm)
Cylinder stroke	33.5 in (850 mm)
Arm cylinder	One (1)
Cylinder bore	3.9 in (100 mm)
Cylinder rod diameter	2.6 in (65 mm)
Cylinder stroke	29.7 in (755 mm)
Bucket cylinder	One (1)
Cylinder bore	3.3 in (85 mm)
Cylinder rod diameter	2.2 in (55 mm)
Cylinder stroke	26.2 in (665 mm)
Boom swing	One (1)
Cylinder bore	3.7 in (95 mm)
Cylinder rod diameter	2.2 in (55 mm)
Cylinder stroke	26.6 in (675 mm)

SERVICE CAPACITIES

Fuel tank	31.7 gal (120 L)
Hydraulic system	25.4 gal (96.3 L)
Hydraulic tank	13.5 gal (51 L)
Engine oil w/ filter	3 gal (11.5 L)
Final drive	0.3 gal (1.1 L)
Cooling system	3.2 gal (12.2 L)

OTHER SPECIFICATIONS

Swing speed	0 – 10.4 RPM
Swing torque	12,500 lb-ft (17 000 N-m)
Swing brake	Mechanical disc
Undercarriage:	
Length	9 ft 4 in (2 845 mm)
Track gauge	6 ft 2 in (1 870 mm)
Carrier rollers – each side	1
Track rollers – each side	5
Shoes – triple grouser – each side	39
Shoe width – std.	1 ft 6 in (450 mm)
Link pitch	6.1 in (154 mm)
Track:	
Chain	Grease lubricated/strutted
Guides	Single
Adjustment	Hydraulic

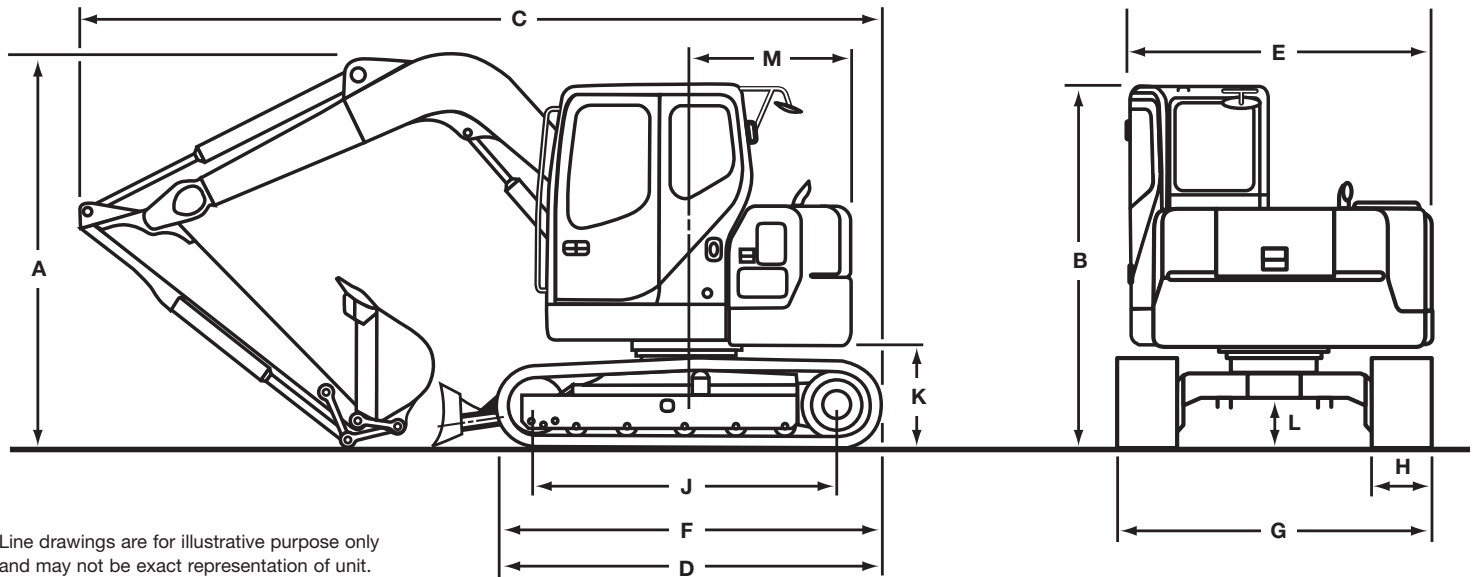

Line drawings are for illustrative purpose only and may not be exact representation of unit.

DIMENSIONS

	5 ft 7 in (1.69 m) Arm	7 ft 2 in (2.19 m) Arm
A. Overall height with attachment	9 ft 1 in (2 760 mm)	9 ft 1 in (2 760 mm)
B. Cab height	9 ft 1 in (2 760 mm)	9 ft 1 in (2 760 mm)
C. Overall length with attachment	21 ft 11 in (6 680 mm)	22 ft 1 in (6 730 mm)
D. Overall length without attachment	11 ft 2 in (3 410 mm)	11 ft 2 in (3 410 mm)
E. Width of upper structure	7 ft 5 in (2 270 mm)	7 ft 5 in (2 270 mm)
F. Track overall length	9 ft 4 in (2 845 mm)	9 ft 4 in (2 845 mm)
G. Track overall width with 17.7 in (450 mm) shoes	7 ft 7 in (2 320 mm)	7 ft 7 in (2 320 mm)
H. Track shoe width	1 ft 6 in (450 mm)	1 ft 6 in (450 mm)
Track gauge	6 ft 2 in (1 870 mm)	6 ft 2 in (1 870 mm)
J. Center to center – idler to sprocket	7 ft 3 in (2 210 mm)	7 ft 3 in (2 210 mm)
K. Upper structure ground clearance	2 ft 6 in (750 mm)	2 ft 6 in (750 mm)
L. Minimum ground clearance	1 ft 2 in (360 mm)	1 ft 2 in (360 mm)
M. Rear tail swing radius	5 ft 6 in (1 680 mm)	5 ft 6 in (1 680 mm)
Dozer blade width	7 ft 7 in (2 320 mm)	7 ft 7 in (2 320 mm)
Dozer blade height	1 ft 6 in (450 mm)	1 ft 6 in (450 mm)

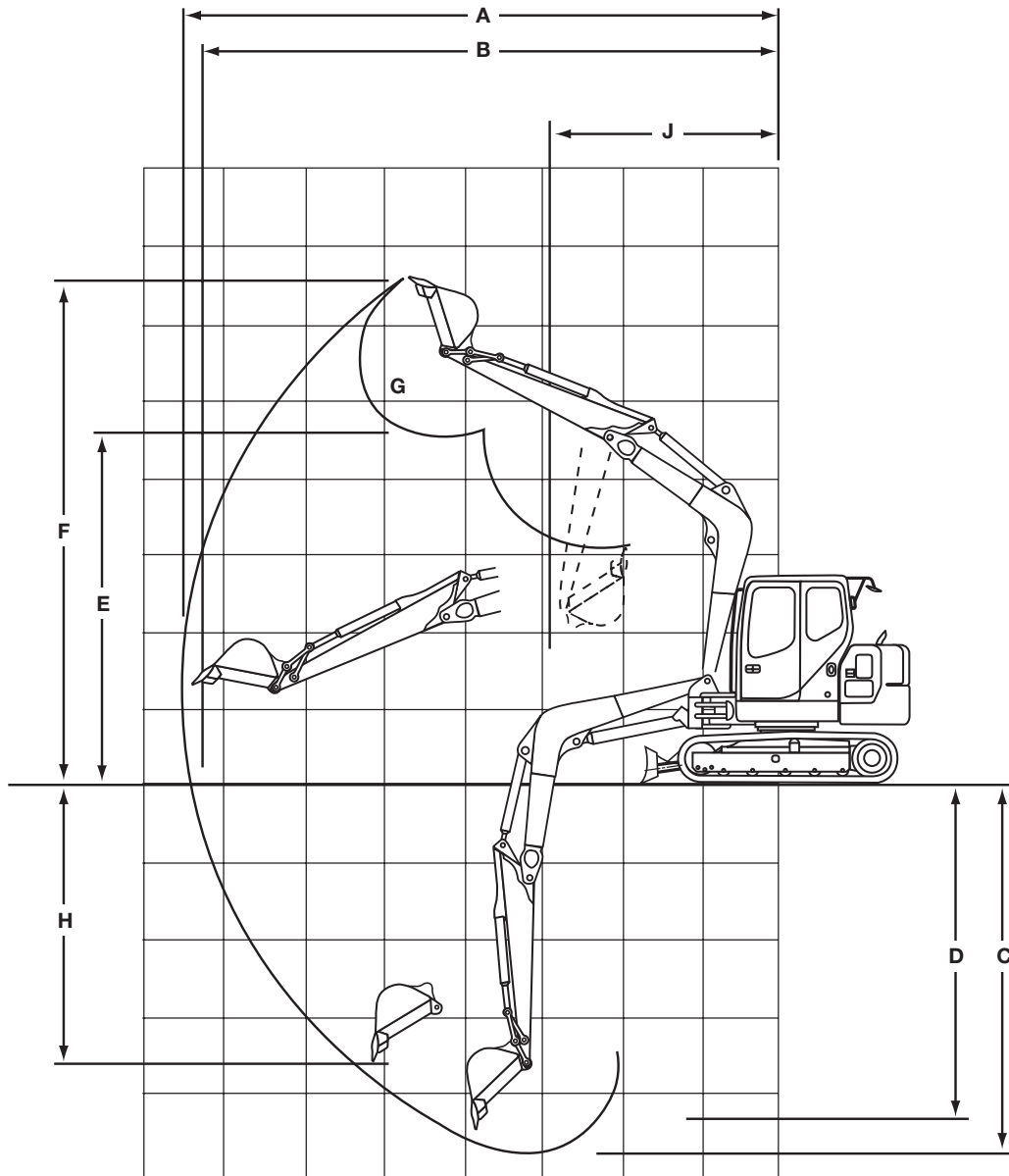

PERFORMANCE SPECS

	5 ft 7 in (1.69 m) Arm	7 ft 2 in (2.19 m) Arm
A. Maximum dig radius	23 ft 3 in (7 090 mm)	24 ft 10 in (7 560 mm)
B. Dig radius at groundline	22 ft 9 in (6 940 mm)	24 ft 4 in (7 420 mm)
C. Maximum dig depth	13 ft 9 in (4 180 mm)	15 ft 4 in (4 670 mm)
D. Dig depth – 8 ft 0 in (2.44 m) level bottom	12 ft 6 in (3 810 mm)	14 ft 4 in (4 360 mm)
E. Dump height	14 ft 10 in (4 530 mm)	15 ft 11 in (4 850 mm)
F. Maximum reach height – maximum dig height	21 ft 7 in (6 570 mm)	22 ft 7 in (6 890 mm)
G. Bucket rotation	177°	177°
H. Maximum vertical wall dig depth	11 ft 0 in (3 350 mm)	12 ft 10 in (3 920 mm)
J. Minimum swing radius	9 ft 2 in (2 790 mm)	9 ft 11 in (3 030 mm)
Arm digging force	8,880 lb (39.5 kN)	7,600 lb (33.8 kN)
Bucket digging force*	12,800 lb (56.9 kN)	12,800 lb (56.9 kN)
Dozer blade cutting edge:		
Maximum height	1 ft 5 in (440 mm)	1 ft 5 in (440 mm)
Maximum depth	11 in (280 mm)	11 in (280 mm)

NOTE: *Digging force ratings based on ISO6015.

LIFT CAPACITIES

5 ft 7 in (1.69 m) Arm Lift capacities using a 450 lb (204 kg) bucket, 2,424 lb (1 100 kg) counterweight with dozer blade on ground.

Load (Lift Point Height)	5 ft (1.5 m)		10 ft (3 m)		15 ft (4.5 m)		20 ft (6 m)		MAXIMUM REACH		
	END	SIDE	END	SIDE	END	SIDE	END	SIDE	@	END	SIDE
+15 ft (4.5 m)					3,700 lb (1 678 kg)	3,700 lb (1 678 kg)			19 ft 4 in (5.89 m)	2,450 lb (1 111 kg)	2,450 lb (1 111 kg)
+10 ft (3 m)					4,400 lb (1 996 kg)	4,000 lb (1 814 kg)	3,800 lb (1 724 kg)	2,500 lb (1 134 kg)	21 ft 9 in (6.63 m)	2,400 lb (1 089 kg)	2,150 lb (975 kg)
+5 ft (1.5 m)			10,050 lb (4 559 kg)	6,950 lb (3 152 kg)	6,050 lb (2 744 kg)	3,750 lb (1 701 kg)	4,400 lb (1 996 kg)	2,400 lb (1 089 kg)	22 ft 5 in (6.83 m)	2,550 lb (1 157 kg)	1,950 lb (885 kg)
Groundline			8,700 lb (3 946 kg)	6,500 lb (2 948 kg)	6,900 lb (3 130 kg)	3,550 lb (1 610 kg)	4,650 lb (2 109 kg)	2,300 lb (1 043 kg)	21 ft 7 in (6.58 m)	2,950 lb (1 338 kg)	2,050 lb (930 kg)
-5 ft (-1.5 m)	7,350 lb (3 334 kg)	7,350 lb (3 334 kg)	11,700 lb (5 307 kg)	6,600 lb (2 994 kg)	6,700 lb (3 039 kg)	3,500 lb (1 588 kg)			19 ft 1 in (5.82 m)	4,050 lb (1 837 kg)	2,450 lb (1 111 kg)
-10 ft (-3 m)			8,450 lb (3 833 kg)	6,750 lb (3 062 kg)					14 ft 5 in (4.39 m)	4,650 lb (2 109 kg)	3,800 lb (1 724 kg)

7 ft 2 in (2.19 m) Arm Lift capacities using a 400 lb (181 kg) bucket, 2,424 lb (1 100 kg) counterweight with dozer blade on ground.

Load (Lift Point) Height	0 ft (0 m)		5 ft (1.5 m)		10 ft (3 m)		15 ft (4.5 m)		MAXIMUM REACH		
	END	SIDE	END	SIDE	END	SIDE	END	SIDE	@	END	SIDE
+20 ft (6 m)									16 ft 7 in (5.05 m)	2,450 lb (1 111 kg)	2,450 lb (1 111 kg)
+15 ft (4.5 m)							3,000 lb (1 361 kg)	2,600 lb (1 179 kg)	21 ft 3 in (6.48 m)	2,100 lb (953 kg)	2,100 lb (953 kg)
+10 ft (3 m)					3,700 lb (1 678 kg)	3,700 lb (1 678 kg)	3,550 lb (1 610 kg)	2,550 lb (1 157 kg)	23 ft 5 in (7.14 m)	2,050 lb (930 kg)	1,900 lb (862 kg)
+5 ft (1.5 m)			8,450 lb (3 833 kg)	7,200 lb (3 266 kg)	5,550 lb (2 517 kg)	3,850 lb (1 746 kg)	4,100 lb (1 860 kg)	2,400 lb (1 089 kg)	23 ft 11 in (7.29 m)	2,200 lb (998 kg)	1,800 lb (816 kg)
Groundline			9,350 lb (4 241 kg)	6,600 lb (2 994 kg)	6,700 lb (3 039 kg)	3,600 lb (1 633 kg)	4,600 lb (2 087 kg)	2,300 lb (1 043 kg)	23 ft 2 in (7.06 m)	2,500 lb (1 134 kg)	1,850 lb (839 kg)
-5 ft (-1.5 m)	6,050 lb (2 744 kg)	6,050 lb (2 744 kg)	11,750 lb (5 330 kg)	6,500 lb (2 948 kg)	6,850 lb (3 107 kg)	3,500 lb (1 588 kg)	4,500 lb (2 041 kg)	2,300 lb (1 043 kg)	23 ft 11 in (7.29 m)	3,250 lb (1 474 kg)	2,150 lb (975 kg)
-10 ft (-3 m)	10,900 lb (4 944 kg)	10,900 lb (4 944 kg)	9,950 lb (4 513 kg)	6,700 lb (3 039 kg)	5,650 lb (2 563 kg)	3,600 lb (1 633 kg)			16 ft 10 in (5.13 m)	4,400 lb (1 996 kg)	3,000 lb (1 361 kg)

LIFT CAPACITIES

5 ft 7 in (1.69 m) Arm Lift capacities using a 450 lb (204 kg) bucket, 2,424 lb (1 100 kg) counterweight operating with dozer blade off ground.

Load (Lift Point Height)	5 ft (1.5 m)		10 ft (3 m)		15 ft (4.5 m)		20 ft (6 m)		MAXIMUM REACH		
	END	SIDE	END	SIDE	END	SIDE	END	SIDE	@	END	SIDE
+15 ft (4.5 m)					3,700 lb (1 678 kg)	3,700 lb (1 678 kg)			19 ft 4 in (5.89 m)	2,450 lb (1 111 kg)	2,450 lb (1 111 kg)
+10 ft (3 m)					4,200 lb (1 905 kg)	3,850 lb (1 746 kg)	2,600 lb (1 179 kg)	2,400 lb (1 089 kg)	21 ft 9 in (6.63 m)	2,250 lb (1 021 kg)	2,050 lb (930 kg)
+5 ft (1.5 m)			7,500 lb (3 402 kg)	6,650 lb (3 016 kg)	3,950 lb (1 792 kg)	3,600 lb (1 633 kg)	2,500 lb (1 134 kg)	2,300 lb (1 043 kg)	22 ft 5 in (6.83 m)	2,050 lb (930 kg)	1,900 lb (862 kg)
Groundline			7,000 lb (3 175 kg)	6,200 lb (2 812 kg)	3,750 lb (1 701 kg)	3,400 lb (1 542 kg)	2,450 lb (1 111 kg)	2,200 lb (998 kg)	21 ft 7 in (6.58 m)	2,150 lb (975 kg)	1,950 lb (885 kg)
-5 ft (-1.5 m)	7,350 lb (3 334 kg)	7,350 lb (3 334 kg)	7,100 lb (3 221 kg)	6,300 lb (2 858 kg)	3,700 lb (1 678 kg)	3,350 lb (1 520 kg)			19 ft 1 in (5.82 m)	2,600 lb (1 179 kg)	2,350 lb (1 066 kg)
-10 ft (-3 m)			7,250 lb (3 289 kg)	6,500 lb (2 948 kg)					14 ft 5 in (4.39 m)	4,050 lb (1 837 kg)	3,650 lb (1 656 kg)

7 ft 2 in (2.19 m) Arm Lift capacities using a 400 lb (181 kg) bucket, 2,424 lb (1 100 kg) counterweight operating with dozer blade off ground.

Load (Lift Point) Height	0 ft (0 m)		5 ft (1.5 m)		10 ft (3 m)		15 ft (4.5 m)		MAXIMUM REACH		
	END	SIDE	END	SIDE	END	SIDE	END	SIDE	@	END	SIDE
+20 ft (6 m)									16 ft 7 in (5.05 m)	2,450 lb (1 111 kg)	2,450 lb (1 111 kg)
+15 ft (4.5 m)							2,700 lb (1 225 kg)	2,500 lb (1 134 kg)	21 ft 3 in (6.48 m)	2,100 lb (953 kg)	2,100 lb (953 kg)
+10 ft (3 m)					3,700 lb (1 678 kg)	3,700 lb (1 678 kg)	2,650 lb (1 202 kg)	2,450 lb (1 111 kg)	23 ft 5 in (7.14 m)	2,000 lb (907 kg)	1,850 lb (839 kg)
+5 ft (1.5 m)			7,750 lb (3 515 kg)	6,900 lb (3 130 kg)	4,050 lb (1 837 kg)	3,650 lb (1 656 kg)	2,550 lb (1 157 kg)	2,300 lb (1 043 kg)	23 ft 11 in (7.29 m)	1,850 lb (839 kg)	1,700 lb (771 kg)
Groundline			7,100 lb (3 221 kg)	6,250 lb (2 835 kg)	3,800 lb (1 724 kg)	3,450 lb (1 565 kg)	2,450 lb (1 111 kg)	2,200 lb (998 kg)	23 ft 2 in (7.06 m)	1,950 lb (885 kg)	1,750 lb (794 kg)
-5 ft (-1.5 m)	6,050 lb (2 744 kg)	6,050 lb (2 744 kg)	7,050 lb (3 198 kg)	6,200 lb (2 812 kg)	3,700 lb (1 678 kg)	3,350 lb (1 520 kg)	2,400 lb (1 089 kg)	2,200 lb (998 kg)	23 ft 11 in (7.29 m)	2,250 lb (1 021 kg)	2,050 lb (930 kg)
-10 ft (-3 m)	10,900 lb (4 944 kg)	10,900 lb (4 944 kg)	7,200 lb (3 266 kg)	6,400 lb (2 903 kg)	3,850 lb (1 746 kg)	3,450 lb (1 565 kg)			16 ft 10 in (5.13 m)	3,150 lb (1 429 kg)	2,850 lb (1 293 kg)

STANDARD EQUIPMENT

ENGINE

Isuzu four-cylinder turbo-charged diesel
Tier 4 Final Certified
Electronic fuel injection
Neutral safety start
Auto-engine warm up
Glow-plug pre-heat
One-touch idle
Dual-stage fuel filtration
Dual element air filter
Remote oil filter
Green plug oil drain
500-hour engine oil change interval
24 Volt system
Color LCD monitor
Auto idle shutdown system

HYDRAULICS

ISO pattern controls
5,000-hour hydraulic oil change interval
1,000-hour hydraulic filter change interval
Mechanical disc brakes
Three (3) work mode settings

UPPER STRUCTURE

Right and left side mirrors
Viscous mounted cab – fluid
Common key vandal locks
Upper mounted work light – 70 watt
Cab mounted work light – 70 watt
Swivel guard belly pan

ATTACHMENTS

Boom
Arm – 5 ft 7 in (1.69 m)
Boom mounted work light – 70 watt
Attachment cushion valve

OPERATOR ENVIRONMENT

See page 1

UNDERCARRIAGE

1 ft 6 in (450 mm) steel shoes, triple semi-grouser
Full overlap turntable bearing tub
Front track chain guides
Hydraulic track adjustment
X-pattern carbody

OPTIONAL EQUIPMENT

HYDRAULICS

Auxiliary hydraulics:
Single acting
Double acting
Proportional controls

ATTACHMENTS

Arm – 7 ft 2 in (2.19 m)
Coupler/Case multi-pin grabber
Heavy-duty bucket

UNDERCARRIAGE

23.6 in (600 mm) steel shoes, triple semi-grouser*
1 ft 6 in (450 mm) rubber pads bolted to standard rail
1 ft 6 in (450 mm) full rubber tracks

*Note: Blade will not fully cover 23.6" shoe

OPERATOR ENVIRONMENT

Control pattern selector
FOPS cab top guard – Level 2
Front grill guard – 2 x 2 screen mesh
Front rock guard:
Vertical bars – fixed/one piece/OPG 2
Rear camera

BUCKETS / CASE COUPLER

Application	Width SAE	Heaped Capacity
Pin on/heavy-duty	18 in (457 mm) to 42 in (1 067 mm)	0.21 yd ³ to 0.57 yd ³
Coupler/heavy-duty	18 in (457 mm) to 42 in (1 067 mm)	0.24 yd ³ to 0.59 yd ³
Case multi-fit coupler	—	—
Direct Link Thumb	—	—

CaseCE.com

©2019 CNH Industrial America LLC. All rights reserved. CASE is a trademark registered in the United States and many other countries, owned by or licensed to CNH Industrial N.V., its subsidiaries or affiliates. CNH Industrial Capital is a trademark in the United States and many other countries, owned by or licensed to CNH Industrial N.V., its subsidiaries or affiliates. Printed in U.S.A. Contains 10% post-consumer fiber.

IMPORTANT: CASE Construction Equipment Inc. reserves the right to change these specifications without notice and without incurring any obligation relating to such change. Availability of some models and equipment builds vary according to the country in which the equipment is used. The illustrations and text may include optional equipment and accessories and may not include all standard equipment. Your CASE dealer/distributor will be able to give you details of the products and their specifications available in your area.



CASE Construction Equipment is biodiesel-friendly. NOTE: All engines meet current EPA emissions regulations. All specifications are stated in accordance with SAE Standards or Recommended Practices, where applicable.



Always read the Operator's Manual before operating any equipment. Inspect equipment before using it, and be sure it is operating properly. Follow the product safety signs and use any safety features provided.

Form No. CCE201905CX80CDB
Replaces Form No. CCE201701CX80CDB

CX80C DB