



ROADSAVER III G[®]

SLURRY SEAL & MICROSURFACING MACHINE



INTERNATIONAL



**THE FUTURE IS
GREEN**

Designed by operators, *for* operators, and further refined by engineers; all systems have been optimized to provide the ultimate in reliability, dependability, and ease of operation.

With the precise control necessary for Micro-Surfacing, the **RoadSaver IIIIG** is the Operator's Choice for comfort and ease of operation. All functions of the machine may be monitored with a glance or controlled by fingertip, allowing the operator's attention to remain focused on the material being applied.

Engineered with 21st Century Technology, heavy duty, top-of-the-line components, solid-state electronics, service after the sale, plus proven return on investment—make the **RoadSaver IIIIG** the "Owner's Choice!"

1 **PACCAR MX - ENGINE**

This new **PACCAR** truck engine has increased, low end torque allowing the removal of the side engine. The Traditional RoadSaver power is still available from engine idle through full range of operational speed. The newly designed machine runs quieter and reduces the air quality concerns inherent in older equipment.

2 **SIDE ENGINE REPORTING REQUIREMENTS ARE NOW ELIMINATED!**

This system includes a REPTO design with a hot shift feature including specific safety elements to protect you and your crew.

- Night Light Package for night work operations
- Additive Recirculation/Blending System
- RoadSaver IIIIG Additive Plus Metering System
- Increased capacity emulsion and water tanks
- Dual Compartment-Secondary Tank, with individual pumps and precision metering systems, for post-adding additional polymers and specialized additives into the slurry or micro-surfacing system
- Battery Box Enclosure, with 2-12VDC 970 CCA (Recommended if doing large night work projects)
- Custom features fabricated for your needs
- Crew field training and consulting

3 **EMULSION FILTERING SYSTEM**

With the advancements in technology, we are able to mount the emulsion pump below the tank allowing an increase in available head pressure. The new location dramatically improves the pumps performance and reduces problems from cavitation. This design also includes a high volume suction filter that eliminates pump blockage from emulsion shot/contamination.

4 **TWIN DRIVE/TWIN SHAFT PUGMILL**

Featuring twin hydraulic drives for balanced torque, this reversible, twin shaft pugmill has infinitely variable speed control. Precision design and thorough field testing assures high productivity and product uniformity. The hydraulic diverter and pugmill gate guarantee even distribution and operator control of material supplied to the box.

5 **SMART OPS SYSTEM/ COMPUTERIZED DISPLAYS**

State-of-the-art electronic sensors and displays provide the real time system information on water, aggregate, emulsion, and mineral filler rates. Should the electronic sensors detect any deviation from preset tolerances, an instantaneous signal will instruct the machine to initiate an automatic shut-down sequence or, if selected, sound an alarm.

6 **DRY ADDITIVE SYSTEM**

Hydraulically driven, infinitely variable, removable fines feeder with digital ratio meter allowing precise adjustment from operator control center.

7 **OPERATOR CONTROL CENTER**

"The heart of the RoadSaver IIIIG", this unique feature employs twin joysticks to control the following functions: one button sequenced start, engine throttle control, spreader box lift, shift and auger control, pugmill gate control, diverter gate control, and vibrator control.

Learn more about how the **RoadSaver IIIIG** can help increase your profits and put your company on the **Road to Opportunity.**

We also build the *RoadSaver II-E Model*



RoadSaver III G - Over two decades of field use and testing has proven the RoadSaver's claim of **RELENTLESS RELIABILITY**, now also **ENVIRONMENTALLY FRIENDLY**.



2 SIDE ENGINE REPORTING REQUIREMENTS NOW ELIMINATED!

6 DRY ADDITIVE SYSTEM



3 EMULSION FILTERING SYSTEM



PACCAR MX

1 PACCAR MX - ENGINE

5 SMART OPS SYSTEM/
COMPUTERIZED DISPLAYS



7 OPERATOR CONTROL CENTER



4 TWIN DRIVE/
TWIN SHAFT PUGMILL

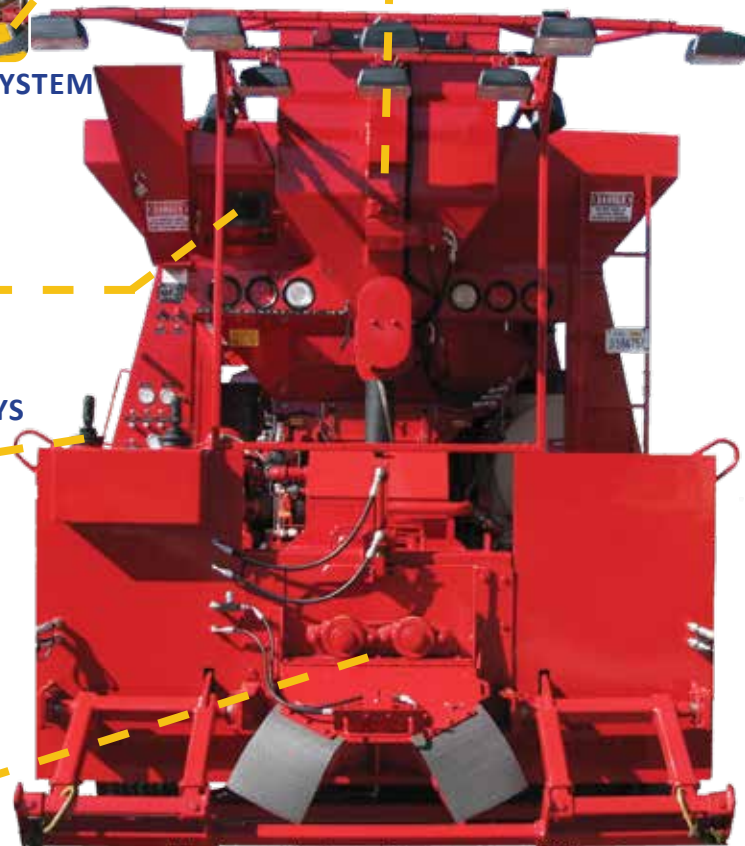

Specifications

Dimensions	US	Metric
Length	26 Ft	7.8 M
Width	8.0 Ft	2.4 M
Height Above Frame	7.0 Ft	2.1 M

Capacities

Aggregate Bin	12 Cu. Yds.	9.2 M3
Water Tank	800 Gallons	3,040 L
Emulsion Tank	800 Gallons	3,040 L
Additive Tank	90 Gallons	340 L
Fines Feeder	16 Cu. Ft.	.45 M3

OPERATOR CONTROL CENTER - An industry first. Twin joysticks control the following functions: One button sequences start/stop, engine throttle control, spreader box lift, box side shift and auger control, pugmill gate control, diverter left/right control and vibrator control. The ease of and convenience of this advanced innovation make the **RoadSaver IIIG** the Operator's Choice in Slurry Machines.

ENGINE - PACCAR MX truck engine has eliminated the need for a side engine. Full power for all functions throughout the operating speeds of the RoadSaver.

ELECTRIC/HYDRAULIC CONTROL SYSTEM

- Patterned after the design of aerospace control systems, this advanced feature performs hydraulic functions based on electrical input and system demand. Complete system redundancy is built in through a fail-safe override system for all critical systems, insuring the ability to "finish the job".

HYDRAULIC SYSTEM - Premium Sauer Danfoss hydraulic components provide dependability and worldwide support. Each pump powers its own system. One fixed pressure pump powers the accessory manifold, while the load sensing pump powers the pugmill drives and the emulsion pump/ conveyor belt and spreader box systems. • Each hydraulic pump has its own filter and separator assembly, to not only filter, but to eliminate both ferrous and nonferrous particles. • Reserve cooling capacity allows full productions on the hottest of days. • True hydraulic fittings used throughout, bulkhead fittings where necessary.

EMULSION DELIVERY SYSTEM - A positive displacement pump is used for long life and consistent output. Both the emulsion pump and the emulsion valve are heat jacketed and warmed by the PACCAR engine for those cold morning starts.

TRACTION MASTER CONVEYOR SYSTEM - RES tested, precision engineered, hydraulically driven, aggregate delivery system complete with **RSIIIG** SuperBelt to provide dependability you can count on.

MIXING SYSTEM - Reversible, Twin Shaft-Twin Drive Multi Paddle Pugmill, complete with hydraulic gate and diverter. An infinitely variable RPM range for all working conditions. All bearings are external for minimal maintenance. Digital RPM display at Operator Control Center. Replaceable

carbide wear tips and wear plates. Adjustable water and additive spray bars assure mixing uniformity and predictability. Easy access, slide-in slide-out pugmill.

QUALITY ASSURANCE QUALITY CONTROL

SYSTEM - State-of-the-art electronic sensors and computer displays provide the following system information: • Engine and Machine Diagnostics • Aggregate & Fines Feeder Delivery Rates in RPM. • Water & Additive Rates in GPM. • Out of Material Alarms. • Auto Calibration feature. • Real time mix percentages for maximum operator control! • SAE & Metric Units • Three Languages available: English, Spanish, & Russian (Other Languages available at an additional fee).

The system continuously monitors the RoadSaver's operation. Should electronic sensors detect any deviation from factory preset tolerances, an instantaneous signal will instruct the machine to initiate a shutdown or, if selected, alert the operator.

LIQUID ADDITIVE SYSTEM - Specially designed Corrosive Resistant Polyurethane Tank with hydraulically driven, corrosion resistant steel shaft, Viton Impentra Seal, and stainless steel hardware. Flow meter at Operator Control Center allowing precise adjustment.

DRY ADDITIVE SYSTEM - Hydraulically driven, infinitely variable, removable fines feeder with digital ratio meter allowing precise adjustment from Operator Control Center.

WATER SYSTEM - Hydraulically driven 130 GPM @ 110 PSI (492 L @ 760kPa) pump with diaphragm valve and available digital flow display for precise control. Water pressure is constant regardless of demand.

VIBRATOR SYSTEM - Hydraulically driven vibrator beam suspended in the aggregate hopper with variable frequency and amplitude adjustments. Activated from Operator Control Center and controlled through the computerized Automatic Sequencing System.

ELECTRICAL SYSTEM -12 VDC Negative Ground.

SERVICE, SUPPORT, & TRAINING - RES provides you with a commitment to get your operation up and running and to keep it running! We offer operator, supervisor, and estimator training; and of course, equipment support

Construction

Tanks: 1/4" ASTM A572 High Tensile Steel formed plate construction: Front, Sides, Bottom Sections. Top-Rear Plate Section attached to aggregate hopper are formed 3/16" ASTM A572 High Tensile Steel. All corner seams are overlapped and welded inside and out. Structural Channel stress-relieved tank bracing is also installed to reinforce the tanks interior and exterior weld joints.

Hopper: 3/16" ASTM A572 High Tensile Steel, with the hopper plating formed with the steel grain aligned with the flow of aggregate to the conveyor to reduce wear.

should you ever need it.

FEATURES - Precision engineered structural design, steel reinforcement in the right places. • Advanced Electric over Hydraulic Control System. • Innovative Operator Control Center. • Quality components chosen with your future in mind. • Traction Master Conveyor System. • High Torque Twin Shaft-Twin Drive, Easy Access Pugmill. • Electric over Hydraulic Throttle Controls. • System designs proven over years of demanding job performance. • Hot Water jacketed emulsion pump and valve provides timely valve and pump performance even on those "cold start" days. • Convenience Package: Includes walk around lubrication, aggregate inspection window, camlock fittings, D.O.T. dome covers and ladders both front and rear. • 100% Hydraulic drives, no chains or sprockets. • Security covers for the Operator Control Center and the joysticks. • A protected compartment is built under the pugmill to provide secure mounting of valuable hydraulic components, sealed from weather and work contamination. • Pavement Water Fog/Spray System. • Service and Support.

OPTIONS - Standard Slurry Seal Spreader Box • Auger Package for Standard Slurry Seal Spreader Box • Shoulder Surfacing Box • Rut Box • Emulsion Level Warning System • Truck Mounting • Side Screen Panels for Security against Vandalism • Night Light Package for night work operations • Additive Recirculation/ Blending System • RoadSaver IIIG Additive Plus Metering System • Increased capacity emulsion and water tanks • Dual Compartment-Secondary Tank, with individual pumps and precision metering systems, for post-adding additional polymers and specialized additives into the slurry or micro-surfacing system • Battery Box Enclosure, with 2-12VDC 970 CCA (Recommended if doing large night work projects) • Custom features fabricated for your needs • Crew field training and consulting.



9390 Elder Creek Road
Sacramento, CA 95829
RESRoadSaver.com
916-381-8066

Specifications are subject to change without notice.

Equipment is designed and manufactured by Rayner Equipment Systems, AN ETYNRE INTERNATIONAL COMPANY

Patents: US 7,802,737 B2, US 8,007,162 B2, and US 8,888,015 B2

K-RS3G-21